

## Antecedents of IPR and Cyber Security Laws of Artificial Intelligence in the Resilience of International Finance

Surya, S.<sup>1</sup>, Seetharaman, A.<sup>2</sup>, Maddulety, K.<sup>3</sup>, Girija Shawarika<sup>4</sup>

<sup>1</sup>Research Scholar, SP Jain School of Global Management, Sydney, Australia

<sup>2</sup>Professor cum Dean, SP Jain School of Global Management, Sydney, Australia

<sup>3</sup>Professor cum Deputy Director, SP Jain School of Global Management, Sydney, Australia

<sup>4</sup>Assistant professor, SP Jain School of Global Management, Sydney, Australia

**Email:** <sup>1</sup>[surya.dm24dba010@spjain.org](mailto:surya.dm24dba010@spjain.org); <sup>2</sup>[Seetha.raman@spjain.org](mailto:Seetha.raman@spjain.org),

<sup>3</sup>[k.maddulety@spjain.org](mailto:k.maddulety@spjain.org), <sup>4</sup>[Girija.shawarika@spjain.org](mailto:Girija.shawarika@spjain.org)

**Abstract:** The aspect of affirming the global advancement of technology in ai era, the scope of the research determines the valuable contributions in the area of major setback of cybersecurity law amendment and regulatory framework of artificial intelligence in financial efficiency in international finance, the role to enhance architecture deployment of AI in general to design regulation and policy framework to design a policy framework the safety, ethical, tranquility, efficiency & humanity (seteh) of ai cyber security architecture in sustainable financial domain in legal arena

**Keywords:** Seteh framework, AI in fintech policy and legal regulatory compliance, cybersecurity architecture , human psychology, AI governance

### I. INTRODUCTION

The economy and humans feel the aspect of insecurity and threat if their data are theft or utilized for financial loss and other unethical concerns, yes, we are in generation where the global is aspiring towards artificial intelligence where the human race are exposed to insignificant threats and infinity technological efficiency. The aspect of advancement in technology can make the day-to-day work easier, smarter, efficient and productive, but no technology can provide a adverse effect of inhumanity like artificial intelligence has done. During the year 2023, in the USA, a human has performed suicide due to the irrelevant information provided by the ai during his search of data through ai platform, so can you imagine how adverse the ai tool is it has the power to even take a life, that is 100 times threatening than covid19. So, the reason to indulge this case in this research paper is, there as no proper logic and sense of humanity the ai tool has towards human values, to ai everything has a result that are predesigned, pedagogy and impending data mining that will provide output of data what it has been designed for, can a human tolerance can match its transparency and data asymmetry in terms of information's.

#### 1.1.LITERATURE REVIEW

#### 1.2 AI TOOLS AND ITS SIGNIFICANCE

Basically to understand the ai tool in finance , it has multi functionality dimensions where it has related diversification in providing the humans the ease to transfer money through digital platform, technology has introduced apps like phone pe, Paytm, google pay and it saved human time , and the proportion of ai advancement in organization still has a vibrant inactiveness to get excited to utilise ai because , its entirely not be regulated with laws and safety compliance where there has been cyber- attacks and threats due to

utilizing the ai tool in handling money or for any other purpose, the aspect of gathering information through literature made a broader knowledge expansion in the perspective of variables like cyber threats, fraudulent activities, no proper regulations applied by government , need employee skill training, need of proposed regularized framework to utilize ai, needed robust security and guideline to utilise ai in financial advancement that can create the trust in human minds. In order to address the specified limitations that has been identified by our fellow researcher it is very much valid and significant that there are drawbacks in legal framework and regulations in the ai technology advancement , that proportionate need has to been filled , hence the efficient manner to implement a legal, technological, ethical, safe, human value ,environmental friendly seteh framework will be designed to address the drawback faced by human race after utilising the ai technology. Ensuring the safety and privacy with ethical concerns, the so to be designed legal and policies related to seteh framework needs a well diverse global outlook in implementing the law and regulations that could make human of all categories to utilise ai tool only for positive aspects that protect data's in all domains and services.

### 1.3 AI IN FINANCE

In the literature we could review that human emotions and psychology has been in terms of concerns of conflict , where the ai intelligence and human natural intelligence feel contradicting and conflicting due to which there should be more concern given to ai based psychological tools and human emotional values that can implement the positive aspect of human friendly compatibility tool in every organization from director to all stakeholders that make the process of business ease and finite factors that has direct impact with ai in finance domain are

- a) Regulation
- b) Ethical management
- c) Systematic risk
- d) Human psychology
- e) It infrastructure

The research was broadly described in aspect with security, ethical privacy concerns to data leakage threat while using ai tools, and there has been a proportionate need for scaling up the legal and regulatory aspects of using ai in economy that need of policy making demand which could be determined by implementing seteh framework that ideally combines the legal, human psychology and ai innovation infrastructure aspects to become compatible to every organization and business and services to produce a effective outcome in terms of money, increase in profit and good organizational culture employee involvement factors. The need for flexibility of ai in economy is being stable with, may or may not be producing increase in GDP and exchange rate of money and innovations with respect on change in economic climate and business that should improvise the factors in humans to trust ai tool directly or indirectly for future years or time, based on its technological advancements If there can be a proportionate use of seteh framework that has been ideally designed to collaborate ai in aspects of human psychology, legal, ethical and innovative framework we could provide a evident result in determining the trust quotient can rise between humans and can utilise it in well positive manner rather than using it for negative adverse actions in military and power for destruction of humans.

## 2. RESEARCH FRAMEWORK

The figure represents the variables that have influenced the role of ai tools in the financial domain that could enhance the safety, ethical, tranquility, efficiency & humanity (seteh) of ai technologies in sustainable financial domain in legal arena, The negative aspects variables that are not attended or concentrated in literature that need to be address directly or indirectly to enhance AI tools landscape in international finance includes regulations, ethical management, systematic risk, human psychology and IT infrastructure If these variables and their issues are addressed, we could create a credible enforcement of AI tools in fintech on legal domain, the IT integrity could be enhanced, could expect a very positive return in the market, and can help the humans to idealize the sense of actions and directions towards utilising the AI tools and can improve the system performance if the IT infrastructure has been advanced

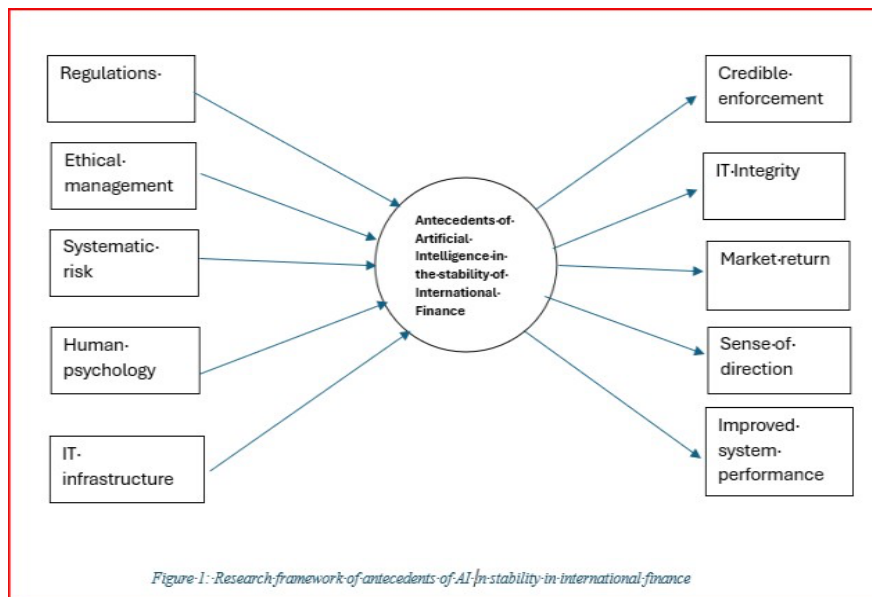

### 2.1 Design/ methodology /approach

The contribution towards achieving the sustainable ai in finance needs a regulated framework that concepts the ratio imbalance between ai mechanisms with machine intelligence in compliance with the regulatory and legal aspects in the economy encompassing of human values, the variable that directly or indirectly influence the legal repository attributes of ai tools in finance domain are cyber-attacks in fintech; that disrupts the privacy & security of technological data; by creating the cyber threats and systematic risks, where the current criminal legal technology compliance in ai aspects are not advanced to determine the fraud detection and fails to engraved the human trust and security factor of emotions. The methodology to determine the role of drawback of ai technology of fintech in legal compliance can be exceptionally witnessed by adopting the qualitative method of data analysis through indulging the case study review findings by skimming

40 case studies. After analyzing the case studies the high priority independent indicators that need to be addressed in the context of ai in fintech is legal regulatory and policy framework of ai that has the dependent variables such as safety ,user privacy factor, ethical factor of systematic risks, the role of authoritative regulatory body of ai human psychology ai policy, ai laws ,& ai infrastructure, innovation research.

Secondly an pilot study has been conducted based on the relation to determine the usage and efficiency of AI in IT law and infrastructure where the influencing factors includes regulations, psychology, risk and ethical management . there were nearly 23 questions framed and that indicates the hypothesis relating to each factors that influence the efficiency of AI and IT law and infrastructure. The questionnaire has been attached in annexure1

The questionnaire has been distributed in social networks like linked, Facebook, PhD research students, professionals in finance sector and other services. The respondents were around 49 people, who are from diverse professional background. considering the inference from Figure 2 below The respondents age where seem to be 48.9% belong to young adult age group of 20-35 years old and remaining 33.3% of people belong to adult age group from 36-50 years old and the remaining 17.8% people belong to older age of 50-65 years. And analyzing from figure 2 83.7% respondents where male and 16.3% respondents where female where taking in to consideration of their working experience from the response from figure 4 we could infer that 34.9% people have more than 15 years of working experience,25.11% of people have professional experience of 10-15 years and 20.9% of people have 6-10 year experience and remaining 18% of people have less that 5 year experience with considering the inference from Figure 5, 64.5% people have completed college graduate degree, 8.9% people have completed college and less that 3% have their DBA and PhD degrees.

Your gender  
43 responses

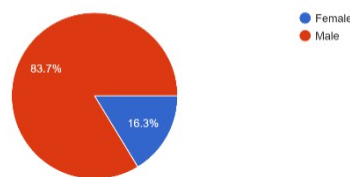

*Figure 2: Marital status of respondents*

Demographic profile Your age  
45 responses

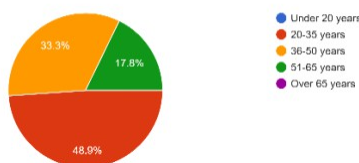

*Figure 3: Age of respondents*

No of years working experience  
43 responses

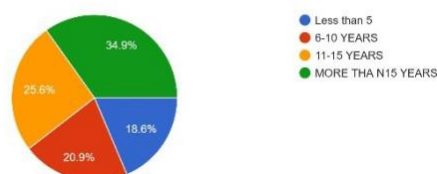
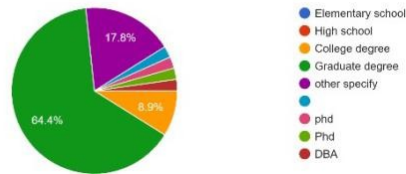

*Figure 4: working experience of respondents*

The target audience in this research includes the people related with usage of ai tools with respect to the diverse domains, see figure 6 that includes 27.3% were professionals

in IT, 27.3% were from service, finance, management, entertainment, 3% where directors, 13.6% where from Manufacturing industries, and remaining where from financial, audit, banking, energy services etc. The below pie chart represents the job position of people who responded this survey.

your highest completed level of education  
45 responses



*Figure 5: education qualification of respondents*

Job position  
44 responses

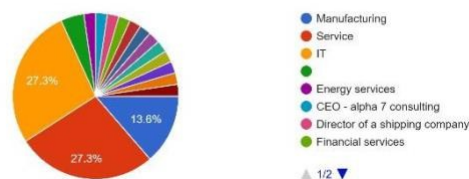

*Figure 6: Job positions of respondents*

## 2.2 Research problem and questions

There are no right and wrong rules while utilising ai tool but will there be a compatibility test mode that still need revision that can meet up human expectations without error, while contrasting the ai tool in financial technology. The recent article in futurism stated that still ai has not been so productive in fintech, where humans feel that it is not user friendly and creates more unemployment, that arises questions in various dimensions like

- Are the regulations still needed for advancement towards ai in the stability of international finance?
- Does ethical management have a significant influence on artificial intelligence in stability of international finance
- How systematic risk has the influence on artificial intelligence in stability of international finance
- Does human psychology have significant relationship with artificial intelligence in stability of international finance
- To what extent it infrastructure influence the artificial intelligence in stability of international finance

This research further deep dives in to the collaboration between ai legal frame work and machine intelligence ai where there can been seen a proportionate distance of human ethics and safety of concern incompatibility that need to be addressed and to determine the indicators that made ai human centric tool a failure, so the broader area of research done in the ai advancement includes the research questions of

### 2.3 Research objectives

- To identify intended regulations which have significant influence on artificial intelligence in stability of international finance
- To evaluate the ethical management which has the significant influence on artificial intelligence in stability of international finance
- To assess the systematic risk which influences artificial intelligence in stability of international finance
- To ascertain the extent of human psychology in influencing artificial intelligence in stability of international finance
- To establish it infrastructure of artificial intelligence in stability of international finance

### 2.4 Discussion analysis and outcome measure

This research has been explained based on consent reviewing and skimming of 50 journals that has clearly stated the advancement of ai tools in fintech, we could rationalize the data obtained in mere information basis and with the relevant collection of data mining through the case studies it has been theoretically significant that there is a need for legal regulatory, ethical and secure framework for ai in finance and other domains related with ai cyber-attacks and data leakage to create a greater impact of danger to business in state or regional or national or international level of economy where at the end its human value and beliefs is what going to suffer in adverse output with utilising the ai, hence the five dimensions which need at most detailing for proper utilization of ai too, are, legal and regulatory aspects, human psychology ,innovation and IT infrastructure, systematic risk in Financial technology and finally cyber security and technology of ethical management aspects.

### 2.5 Structural equation modelling-Direct model

The SEM is one of the methods that are being used to determine the reliability, credibility, convergent validity, determining the value of measure to access the consideration of figure7 with derivative of those dependent variable that influences the efficiency of AI(EAI) fintech tools are ,**RAI**: Regulations in Usage of AI tool, **EM**: Ethical management in Usage of AI tool, **SR**: Systematic Risk analysis of AI tools, **AIHM**: Artificial intelligence and human Psychology, **IT**:IT infrastructure and AI .

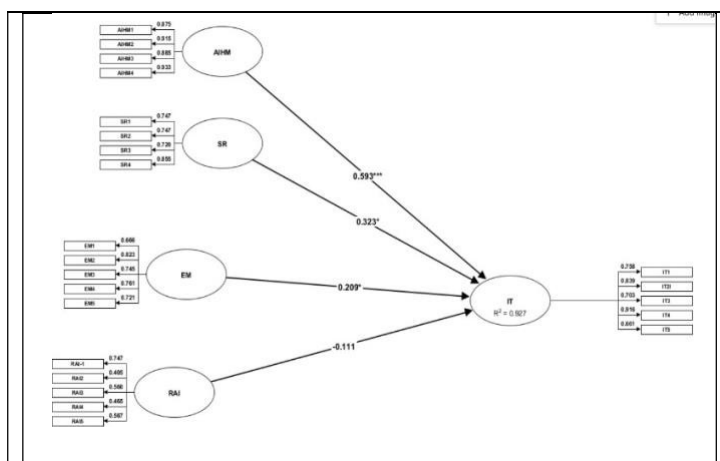

Figure:7 The structural equation modelling of AI in International finance

The artificial intelligence IT infrastructure and law are considered to be the independent variable where from the structural equation modelling analysis we could infer that the reliability of artificial intelligence and human psychology and brain has 99.8% impact on AI IT infrastructure and law then the influence of systematic risk is around 95% over AI IT infrastructure and law finally the impact of ethical management over AI it and infrastructure is around 81%.The least reliability impact is regulations of AI which seems to be around 60% over IT and infrastructure.

**The usage of ADANCO software helps in determining.**

*Descriptive statistics*

The descriptive statistics determines the standard deviation of the model that could enhance the error and outlier removal from the data analysis by data tuning and scaling methods. The lower limit is 2 and the upper limit value of standard deviation is 5, and the maximum value of variance ranges from 0 to 2 .

Indicator	Minimum	Maximum	Mean	Variance	Skewness	Kurtosis
RAI1	1.000000000000	5.000000000000	3.489361702128	1.158326527197	-0.780454678581	0.460232778654
RAI2	1.000000000000	5.000000000000	3.617021276596	1.154486586494	-0.701846477571	-0.055827599217
RAI3	1.000000000000	5.000000000000	3.042553191489	1.172062904718	-0.624247716865	-0.621310562846
RAI4	1.000000000000	5.000000000000	2.872340425532	1.287696577243	0.260783992683	-0.475929404028
RAI5	1.000000000000	5.000000000000	4.148936170213	0.955596669750	-1.186037244555	1.247735446338
EM1	1.000000000000	5.000000000000	3.680851063830	0.743755781684	-0.591691058966	0.925297528639
EM2	2.000000000000	5.000000000000	4.106382978723	0.444958371878	-0.580537629357	1.151805528105
EM3	1.000000000000	5.000000000000	3.489361702128	0.820536540241	-0.425236003537	0.153510346516
EM4	1.000000000000	5.000000000000	3.425531914894	1.032377428307	-0.568116333521	0.408664865793
EM5	1.000000000000	5.000000000000	3.659574468085	0.620721554117	-0.695730097736	1.751068387415
SR1	1.000000000000	5.000000000000	3.276595744681	0.987049028677	-0.594364308147	0.055399249675
SR2	2.000000000000	5.000000000000	4.085106382979	0.514338575393	-0.496720463802	0.325354732565
SR3	2.000000000000	5.000000000000	3.829787234043	0.926919518964	-0.559625864209	-0.508432092447
SR4	1.000000000000	5.000000000000	3.851063829787	0.781683626272	-0.879770491408	1.343756794867
AIHM1	1.000000000000	5.000000000000	3.765957446809	1.096207215541	-1.048338008382	1.218960429483
AIHM2	1.000000000000	5.000000000000	3.531914893617	0.602220166512	-0.402221302224	1.426226545864
AIHM3	1.000000000000	5.000000000000	3.914893617021	0.862164662350	-0.846479354382	0.929707173226
AIHM4	1.000000000000	5.000000000000	3.723404255319	0.656514246968	-0.610236324632	0.475389716712
IT1	1.000000000000	5.000000000000	4.000000000000	0.739130434783	-1.280318113307	2.688036070043
IT2	1.000000000000	5.000000000000	3.914893617021	0.775208140611	-1.425993674397	3.547597632041
IT3	1.000000000000	5.000000000000	4.212765957447	0.779833487512	-1.429266165704	2.864868719873
IT4	1.000000000000	5.000000000000	4.042553191489	0.780758556892	-1.664961515033	4.441965827498
IT5	1.000000000000	5.000000000000	3.595744680851	1.115633672526	-0.725586470127	0.506108234646

Figure 8: descriptive statistics for direct model

*The Construct Reliability*

The model seems to be relating the IT and law variables with respect to factors such as regulations, ethical management, systematic risk analysis, artificial intelligence and human psychology etc. the basic value of the construct reliability should always be more than 0.50 , from the tabulation below we could infer that the value of Cronbach alpha, joreskongsrho value for indicators EM,SR,AIHM for the dependent variable is highly significant and Systematic risk and Human psychology has greater that 0.70 and 0.85 Cronbach alpha value where we could infer that it has greater hypothesis significant in terms of IT infrastructure and Law.

Construct Reliability			
Construct	Dijkstra-Henseler's rho ( $\rho_A$ )	Jöreskog's rho ( $\rho_c$ )	Cronbach's alpha( $\alpha$ )
IT	0.8957	0.8852	0.8812
AIHM	1.0000	0.9461	0.9238
SR	1.0000	0.8523	0.7674
EM	1.0000	0.8612	0.7974
RAI	1.0000	0.6869	0.4190

Figure 9: construct reliability for direct model Convergent Validity,

From the output obtained through the statistical tool Adanco, where the degree of significance plays a crucial role in determining the relatable factor AI information

technology infrastructure and law related to withstand the effect of Artificial intelligence and human brain psychology, systematic risk factors , ethical management and regulations factors in terms of convergent validity where the AI HM, SR,EM seems to be having AVE value more than 0.5 except the regulatory factors hence we could state that there is theoretical relations between all the three factors ove AI IT innovation and law

Construct	Average variance extracted (AVE)
IT	0.6100
AIHM	0.8144
SR	0.5917
EM	0.5550
RAI	0.3143

*Figure 10: convergent reliability for direct model Discriminant Validity based on Fornell-Larcker Criterion,*

The discriminant valididty determines the unrelated corelations between the dependent factors to the independent factors, from the data obtained in the below table we could infer that the discriminat validity exists in the model as the diagnol values are greater than the non diagnol squared value correlations corresponding to their rows and coloumns.

Discriminant Validity: Fornell-Larcker Criterion

Construct	IT	AIHM	SR	EM	RAI
IT	0.6100				
AIHM	0.8513	0.8144			
SR	0.8273	0.7207	0.5917		
EM	0.4906	0.3254	0.4783	0.5550	
RAI	0.2941	0.3314	0.3075	0.4020	0.3143

Squared correlations; AVE in the diagonal.

*Figure 11: discriminant validity for direct model Loadings, (Testing Sub variable alignment with construct) Outer Model*

The convergent validity can also be determined by the construct loadings that are obtained through the analysis with the data collected, the indicator loading having values greater than or equal to 0.7 is said to be significant and satisfactory.

Loadings					
Indicator	IT	AIHM	SR	EM	RAI
RAI-1					0.7466
RAI2					0.4046
RAI3					0.5597
RAI4					0.4647
RAI5					0.5668
EM1				0.6664	
EM2				0.8230	
EM3				0.7450	
EM4				0.7605	
EM5				0.7212	
SR1			0.7474		
SR2			0.7474		
SR3			0.7203		
SR4			0.8547		
AIHM1		0.8747			
AIHM2		0.9154			
AIHM3		0.8852			
AIHM4		0.9333			
IT1	0.7584				
IT2I	0.8392				
IT3	0.7030				
IT4	0.9162				

Figure 12: loadings for direct model Cross Loadings

The cross loadings is one of the statistical equation modelling indicator that determines the relations between the indicators and constructs, the need for clear building of constructs plays a crucial role in correlations between the indicators, from the out put below we could infer that the model is highly correlated with respect to cross loading analysis.

Cross Loadings					
Indicator	IT	AIHM	SR	EM	RAI
RAI-1	0.2265	0.3202	0.1796	0.3367	0.7466
RAI2	0.3855	0.4181	0.4038	0.4331	0.4046
RAI3	0.1434	0.1348	0.1392	0.3558	0.5597
RAI4	0.1233	0.1577	0.2615	0.1851	0.4647
RAI5	0.6087	0.5479	0.5368	0.4282	0.5668
EM1	0.5679	0.3840	0.3943	0.6664	0.3724
EM2	0.5965	0.4892	0.5766	0.8230	0.4950
EM3	0.4643	0.3836	0.5822	0.7450	0.4387
EM4	0.4265	0.4459	0.4868	0.7605	0.5724
EM5	0.5476	0.4171	0.5301	0.7212	0.4777
SR1	0.6466	0.6560	0.7474	0.5781	0.4485
SR2	0.5624	0.5001	0.7474	0.5801	0.3974
SR3	0.7225	0.6552	0.7203	0.4358	0.4241
SR4	0.8608	0.7948	0.8547	0.5291	0.4325
AIHM1	0.7707	0.8747	0.7059	0.4515	0.5534
AIHM2	0.8818	0.9154	0.8574	0.5407	0.5383
AIHM3	0.8101	0.8852	0.7212	0.5466	0.4696
AIHM4	0.8669	0.9333	0.7791	0.5197	0.5160
IT1	0.7584	0.6816	0.6954	0.5456	0.4143
IT2I	0.8392	0.7979	0.7531	0.5982	0.4188
IT3	0.7030	0.6171	0.6655	0.5179	0.3584
IT4	0.9162	0.8583	0.8608	0.5746	0.5154
IT5	0.6609	0.6163	0.5419	0.4991	0.3998

Figure 13 cross loadings for direct model Multicollinearity

The Variance inflation factor should be less than 10 and 5 that means the given factors are not in terms with multicollinearity, hence comparing the value of vif from the table of output below we could infer that the VIF values are less than the specified value and we could state that our model is free from any multicollinearity as the vif value are less than 10 and vf values are less than 5.

Indicator Multicollinearity					
Indicator	IT	AIHM	SR	EM	RAI
RAI-1					1.5254
RAI2					1.0976
RAI3					1.2022
RAI4					1.3309
RAI5					1.0849
EM1				1.3806	
EM2				1.9517	
EM3				1.6455	
11-01-20					
O - Results for FINAL MODEL file://C:/Users/Alienware/AppData/Roaming/ADANCO/temp/re					
EM4				1.7882	
EM5				1.5111	
SR1			1.4614		
SR2			1.4738		
SR3			1.4008		
SR4			2.0387		
AIHM1		2.7927			
AIHM2		3.5486			
AIHM3		3.2033			
AIHM4		4.4995			
IT1	2.4815				
IT2I	4.1406				
IT3	2.6615				
IT4	4.1113				
IT5	1.3776				

Figure 14: multi collinearity for direct model

**Direct effect inferences, Indirect effect inferences, Total effect inferences**

One the P and T values could determine the direct effect of hypothesis relation against null hypothesis, in the case of IT AI effect over the other four dependent factors, from the table of output below we could infer that that value of p >0.05 is insignificant and p<0.05 is significant is the standardization value factor towards hypothesis testing hence , we could infer that the value for AIHM-IT, SR- IT,EM-IT the value of P is 0.05 which empathize that the values are highly significant and it's the evidence reject the null hypothesis. Whereas the RAI-IT P value seem to more than 0.05 which is insignificant and we could not reject the null hypothesis. Considering the T values the values less than 1.65 seem to be insignificant than that of values greater than 1.96, all the three dependent factors AIHM- IT,SR-IT,EM-IT do have the values greater that 1.97 which the hypothesis is highly significant with respect to factor RAI-IT where the value is less than1.65 which is not significant .

Total Effects Inference										
Effect	Original coefficient	Standard bootstrap results					Percentile bootstrap quantiles			
		Mean value	Standard error	t-value	p-value (2-sided)	p-value (1-sided)	0.5%	2.5%	97.5%	99.5%
AIHM -> IT	0.5927	0.5965	0.1658	3.5747	0.0004	0.0002	0.1811	0.2691	0.9220	1.0210
SR -> IT	0.3232	0.3064	0.1524	2.1210	0.0340	0.0170	-0.1176	-0.0134	0.5877	0.6571
EM -> IT	0.2089	0.2032	0.1056	1.9784	0.0479	0.0240	-0.0345	0.0132	0.4287	0.5113
RAI -> IT	-0.1105	-0.0874	0.1186	-0.9324	0.3512	0.1756	-0.3716	-0.3006	0.1690	0.2513

Figure 15: total effects inferences for direct model Model 2: structural equation modelling Intermediate factors model

The SEM is one of the methods that are being used to determine the reliability, credibility, convergent validity, determining the value of measure to access the consideration of figure7 with derivative of those dependent variable that influences the efficiency of AI(EAI) fintech tools are ,**RAI**: Regulations in Usage of AI tool, **EM**: Ethical management in Usage of AI tool, **SR**: Systematic Risk analysis of AI tools, **AIHM**: Artificial intelligence and human Psychology, **IT**:IT infrastructure and AI .

The artificial intelligence IT infrastructure and law are considered to be the independent variable where from the structural equation modelling analysis we could infer that the reliability of artificial intelligence and human psychology factor towards systematic risk as the intermediate variable has 98% influence but there seem to be no impact with IT infrastructure and law .

and brain has more that 99.8% impact on AI IT infrastructure and law then the influence of systematic risk is around 95% over AI IT infrastructure and law the impact of ethical management over AI it and infrastructure is around 81%.The least reliability impact is regulations of AI which seems to be around 60% over IT and infrastructure.

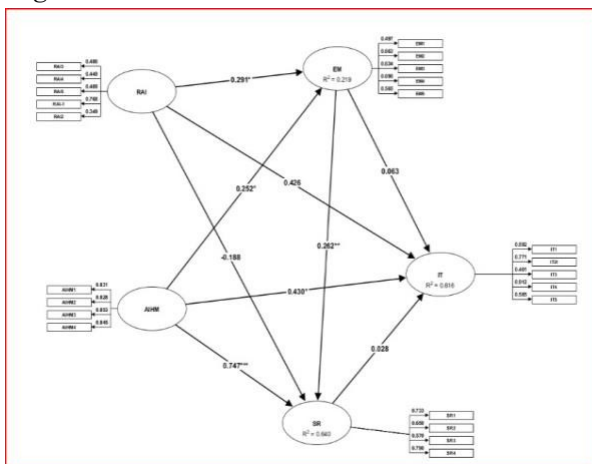

Figure :16 The structural equation modelling of AI in International finance

**Construct Reliability**

Construct	Dijkstra-Henseler's rho (ρ <sub>A</sub> )	Jöreskog's rho (ρ <sub>c</sub> )	Cronbach's alpha(α)
RAI	1.0000	0.6413	0.2821
EM	1.0000	0.7505	0.5810
SR	1.0000	0.7826	0.6246
AIHM	1.0000	0.9051	0.8601
IT	0.8429	0.7962	0.7976

Figure 17: descriptive statistics for indirect model

The model seems to be relating the IT and law variables with respect to factors such as regulations, ethical management, systematic risk analysis, artificial intelligence and human psychology etc. the basic value of the construct reliability should always be more than 0.50 , from the tabulation below we could infer that the value of Cronbach alpha, joreskongsrho value for indicators EM,SR,AIHM for the dependent variable is highly significant and Systematic risk and Human psychology has greater that 0.70 and 0.85 Cronbach alpha value where we could infer that it has greater hypothesis significance in terms of IT infrastructure and Law.

*Descriptive statistics*

The descriptive statistics determines the standard deviation of the model that could enhance the error and outlier removal from the data analysis by data tuning and scaling methods. The lower limit is 2 and the upper limit value of standard deviation is 5, and the maximum value of variance ranges from 0 to 2 .

Descriptive statistics					
Indicator	Minimum	Maximum	Mean	Variance	Skewness
RAI-1	1.000000000000	5.000000000000	3.489361702128	1.168362627197	-0.78045467858
RAI2	1.000000000000	5.000000000000	3.617021276596	1.154486586494	-0.70184647757
RAI3	1.000000000000	5.000000000000	3.042553191489	1.172082904718	-0.62424771666
RAI4	1.000000000000	5.000000000000	2.872340425532	1.287696577243	0.26078399268
RAI5	1.000000000000	5.000000000000	4.148936170213	0.955596969750	-1.18603724455
EM1	1.000000000000	5.000000000000	3.680851093830	0.743755781684	-0.59169105896
EM2	2.000000000000	5.000000000000	4.108382978723	0.444958371878	-0.58053762935
EM3	1.000000000000	5.000000000000	3.489361702128	0.820536540241	-0.42523600353
EM4	1.000000000000	5.000000000000	3.425531914894	1.032377428307	-0.56811633352
EM5	1.000000000000	5.000000000000	3.659574468085	0.620721554117	-0.69573009773
SR1	1.000000000000	5.000000000000	3.276595744681	0.987049028677	-0.59436430814
SR2	2.000000000000	5.000000000000	4.085106382979	0.514338575393	-0.49672046380
SR3	2.000000000000	5.000000000000	3.829787234043	0.926919519984	-0.55962586420
SR4	1.000000000000	5.000000000000	3.851063829787	0.781683626272	-0.87977049140
AIHM1	1.000000000000	5.000000000000	3.765957446809	1.096207215541	-1.04833800838
AIHM2	1.000000000000	5.000000000000	3.531914893617	0.602220166512	-0.40222130222
AIHM3	1.000000000000	5.000000000000	3.914893617021	0.862164662350	-0.84647935438
AIHM4	1.000000000000	5.000000000000	3.723404255319	0.856614246068	-0.61023632483
IT1	1.000000000000	5.000000000000	4.000000000000	0.739130434783	-1.28631811330
IT2	1.000000000000	5.000000000000	3.914893617021	0.775208140611	-1.42599367439
IT3	1.000000000000	5.000000000000	4.212765957447	0.779833487512	-1.42926616570
IT4	1.000000000000	5.000000000000	4.042553191489	0.780758556892	-1.06496151503
IT5	1.000000000000	5.000000000000	3.595744680851	1.115633672525	-0.72558647012

Figure18: construct reliability for indirect model

*Convergent Validity*

From the output obtained through the statistical tool Adanco, where the degree of significance plays a crucial role in determining the relatable factor AI information technology infrastructure and law related to withstand the effect of Artificial intelligence and human brain psychology, systematic risk factors , ethical management and regulations factors in terms of convergent validity where the AI HM, to be having AVE value more than 0.5 except the regulatory factors hence we could state that there is theoretical relations between all the three factors over AI IT innovation and law

Convergent Validity	
Construct	Average variance extracted (AVE)
RAI	0.2778
EM	0.3789
SR	0.4773
AIHM	0.7045
IT	0.4558

Figure 19: convergent reliability for indirect model

*Discriminant Validity based on Fornell-Larcker Criterion*

The discriminant validity determines the unrelated corelations between the dependent factors to the independent factors, from the data obtained in the below table we could infer

that the discriminant validity exists in the model as the diagonal values are greater than the non diagonal squared value correlations corresponding to their rows and columns.

Discriminant Validity: Fornell-Larcker Criterion

Construct	RAI	EM	SR	AIHM	IT
RAI	0.2778				
EM	0.1699	0.3789			
SR	0.0785	0.2278	0.4773		
AIHM	0.2322	0.1535	0.5765	0.7045	
IT	0.4444	0.1762	0.2530	0.4629	0.4558

Squared correlations; AVE in the diagonal.

Figure 20: discriminant validity for indirect model Loadings, (Testing Sub variable alignment with construct) Outer Model

The convergent validity can also be determined by the construct loadings that are obtained through the analysis with the data collected, the indicator loading having values greater than or equal to 0.7 is said to be significant and satisfactory.

Loadings

Indicator	RAI	EM	SR	AIHM	IT
RAI-1	0.7684				
RAI2	0.3492				
RAI3	0.4859				
RAI4	0.4487				
RAI5	0.4890				
EM1		0.4970			
EM2		0.6630			
EM3		0.6337			
EM4		0.6982			
EM5		0.5647			
SR1			0.7329		
SR2			0.6499		
SR3			0.5701		
SR4			0.7903		
AIHM1				0.8310	
AIHM2				0.8283	
AIHM3				0.8530	
AIHM4				0.8448	
IT1					0.5923
IT2I					0.7705
IT3					0.4006
IT4					0.9124
IT5					0.5846

Figure 21: loadings for direct model Cross Loadings

The cross loadings is one of the statistical equation modelling indicator that determines the relations between the indicators and constructs, the need for clear building of constructs plays a crucial role in correlations between the indicators, from the out put below we could infer that the model is highly correlated with respect to cross loading analysis

Cross Loadings						
Indicator	RAI	EM	SR	AIHM	IT	
RAI-1	0.7684	0.3059	0.0527	0.2959	0.4240	
RAI2	0.3492	0.2716	0.2287	0.3446	0.4796	
RAI3	0.4859	0.1704	-0.1364	0.0021	0.0614	
RAI4	0.4487	0.2346	0.2675	0.1923	0.2458	
RAI5	0.4890	0.0649	0.2994	0.3897	0.4832	
EM1	0.1669	0.4970	0.0846	0.1516	0.3341	
16-01						
file:///C:/Users/Alienware/AppData/Roaming/ADANCO/temp						
EM2	0.3029	0.6630	0.2080	0.2459	0.3755	
EM3	0.2016	0.6337	0.4845	0.2552	0.2252	
EM4	0.3826	0.6982	0.3632	0.3703	0.2036	
EM5	0.2060	0.5647	0.3185	0.1745	0.1444	
SR1	0.2279	0.4337	0.7329	0.6392	0.4598	
SR2	0.1221	0.4084	0.6499	0.3599	0.2280	
SR3	0.2120	0.1654	0.5701	0.4191	0.2389	
SR4	0.2065	0.3017	0.7903	0.6645	0.4531	
AIHM1	0.3411	0.3028	0.6645	0.8310	0.4537	
AIHM2	0.2867	0.2829	0.7452	0.8283	0.3830	
AIHM3	0.4807	0.4213	0.5641	0.8530	0.6670	
AIHM4	0.5093	0.3083	0.5751	0.8448	0.7804	
IT1	0.4416	0.2536	0.2902	0.3598	0.5923	
IT2i	0.4514	0.3632	0.3832	0.5639	0.7705	
IT3	0.3787	0.1685	0.1244	0.2200	0.4006	
IT4	0.5810	0.3007	0.5293	0.6461	0.9124	
IT5	0.3903	0.3160	0.2507	0.3857	0.5846	

Figure 22: cross loadings for direct model Indicator Multicollinearity

The Variance inflation factor should be less than 10 and 5 that means the given factors are not in terms with multicollinearity, hence comparing the value of vif from the table of output below we could infer that the VIF values are less than the specified value and we could state that our model is free from any multicollinearity as the vif value are less than 10 and vf values are less than 5.

Total Effects Inference										
Effect	Original coefficient	Standard bootstrap results					Percentile bootstrap quantiles			
		Mean value	Standard error	t-value	p-value (2-sided)	p-value (1-sided)	0.5%	2.5%	97.5%	99.5%
RAI -> EM	0.2910	0.2887	0.1413	2.0508	0.0395	0.0197	-0.0951	0.0045	0.5653	0.6618
RAI -> SR	-0.1116	-0.1106	0.1324	-0.8432	0.3992	0.1996	-0.4270	-0.3538	0.1638	0.2671
16-01-2025, 1										
file:///C:/Users/Alienware/AppData/Roaming/ADANCO/temp/result										
RAI -> IT	0.4412	0.3531	0.2713	1.6281	0.1040	0.0520	-0.2752	-0.1594	0.7505	0.8207
EM -> SR	0.2820	0.2830	0.0832	2.8098	0.0050	0.0025	0.0221	0.0737	0.4448	0.5106
EM -> IT	0.0698	0.1022	0.1247	0.5601	0.5754	0.2877	-0.2151	-0.1411	0.3489	0.4310
SR -> IT	0.0276	0.0918	0.2361	0.1168	0.9070	0.4535	-0.4250	-0.3185	0.5852	0.7046
AIHM -> EM	0.2516	0.2383	0.1422	1.7693	0.0769	0.0385	-0.1788	-0.0523	0.4997	0.5696
AIHM -> SR	0.8131	0.7911	0.0696	8.4142	0.0000	0.0000	0.4853	0.5806	0.9591	1.0090
AIHM -> IT	0.4878	0.5803	0.2829	1.5970	0.1103	0.0552	0.0525	0.1303	1.0680	1.1336

Figure 23 multi collinearity for direct model

*Direct effect inferences, Indirect effect inferences, Total effect inferences*

One the P and T values could determine the direct effect of hypothesis relation against null hypothesis, in the case of IT AI effect over the other four dependent factors, from the table of output below we could infer that that value of p >0.05 is insignificant and p <0.05

is significant is the standardization value factor towards hypothesis testing hence , we could infer that the value for RAI-EM,EM-SR,AIHM-EM,AIHM-SR, the value of P is 0.05 which empathize that the values are highly significant and it's the evidence reject the null hypothesis. Whereas the P value seem to more than 0.05 which is insignificant and we could not reject the null hypothesis. Considering the T values the values less than 1.65 seem to be insignificant than that of values greater than 1.96, all the three dependent factors AIHM-IT,SR-IT,EM-IT do have the values greater that 1.97 which the hypothesis is highly significant with respect to factor RAI-IT where the value is less than1.65 which is not significant .

Indicator	RAI	EM	SR	AIHM	IT
RAI-1	1.4879				
RAI2	1.0990				
RAI3	1.2021				
RAI4	1.3465				
RAI5	1.0523				
EM1		1.0784			
EM2		1.2166			
EM3		1.2819			
EM4		1.4546			
EM5		1.1454			
SR1			1.3369		
SR2			1.2383		
SR3			1.1169		
SR4			1.4939		
AIHM1				2.1291	
AIHM2				2.1082	
AIHM3				2.5670	
AIHM4				2.4959	
IT1					1.7178
IT21					2.9192
IT3					1.7733
IT4					2.8375
IT5					1.1568

Figure 24::total effects inferences for direct model

### 3. SOCIAL DIMENSION DISCUSSION AND ANALYSIS WITH HYPOTHESIS GENERATION

*3.1 hypothesis 1: Discussion:* The variable regulations have to be revised in-order to address the drawback faced in AI technology in financial domain, there has been frequent misconduct of regulations some of the negative connotations includes lack in technical expertise, to improve the cybersecurity landscape, and policy regulations that can further enhance flexibility of usage of AI tools for consumers friendly aspects. The negative factors that govern the durability and enforcement of regulations in AI technology includes

1. Shortage of technical expertise
2. Ethical and regulatory laws
3. Development of the AI ecosystem
4. Governance
5. Evolving cybersecurity landscape
6. Policymakers, urban planners, and technology leaders
7. Regulatory frameworks

8. Relevance, coherence and timeliness of the law.
9. AI in legal contexts WITH machine-simulated intelligence
10. New legislation, compliance with existing law without hindering innovation or competitiveness
11. Empirical legal research is required to analyse how well regulating AI systems works in action, in the interaction between law, technology, and society
12. Legal, and technical scrutiny of data *Outcome:*

**The hypothesis generation**

**H1: To test the regulations of AI influence the AI Legal infrastructure and innovation landscape.**

	AI technology regulations to utilize it in financial technology services			
H1d	privacy in using AI tools.	0.465	1.3465	weak
H1e	AI tools require legal standardization in data protection	0.567	1.023	weak

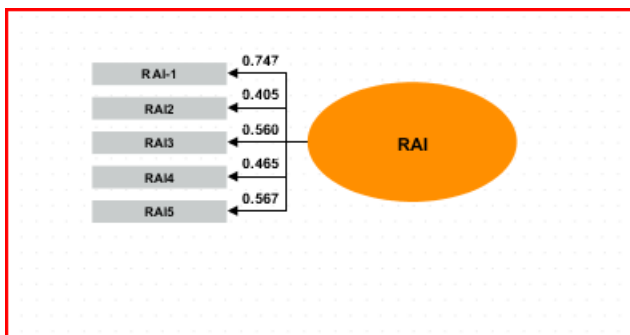

Figure 3.1A: Loading estimates for determinants of Regulations

The figure 3.1 A shows the significant effect of the regulations of AI influence the AI Legal infrastructure and innovation landscape with factors like privacy, ease of using AI tools, privacy, regulations compatibility etc.

**Hypothesis1(H3): the regulations of AI influence the AI Legal infrastructure and innovation landscape.**

**Research question:** How significantly does the regulations of AI influence the AI Legal infrastructure and innovation landscape.  
 Hypothesis1(H1): the regulations of AI influence the AI Legal infrastructure and innovation landscape.

No	Determination of hypothesis	Loadings > 0.8 Strong 0.5 < L < 0.8 Moderate	t-values t > 2.59 Strongly Significant	Inference on Loadings
H1a	AI tools being used in your day today financial activities	0.747	1.4579	moderate
H1b	data has been Breached while using AI tools	0.405	1.0990	weak
H1C	organization comply with	0.560	1.2021	weak

**H3-To test the effect of regulations of AI (RAI) on IT AI infrastructure innovation and Law(IT) in the international finance**

The relationship between the regulations of AI over IT law and infrastructure plays a crucial role in terms of determining the relationship with T VALUES 0.547, WHERE THE REGULATIONS IS MUCH INFLUENCING ITS IMPACT OVER AIIT law and infrastructure.

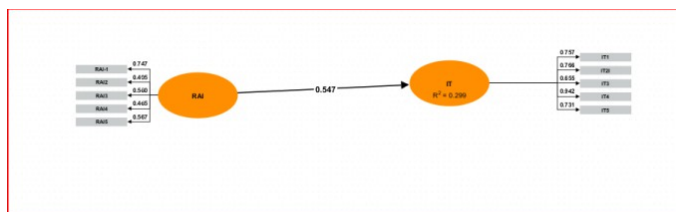

Figure 3.1B: Effect of Regulations AI on IT Infrastructure and law

The enhancement in implementation of Legal model of data processing in AI technology can indeed improve the data flow filtration of protection of data that can be outperformed with adopting a legal and regulatory conceptual model in defining the data are obliged to regulations to pass through the out solution while utilising the AI tools

*Preposition:* with advent of utilising the AI tools, the basic aspect of data and their security has the importance to be protected and henceforth the proposed detailing of law and regulatory division of AI has to determine the credibility of value of Security and protection to data either in corporate world, personal usage or industrial aspects, the need for usage of technical aspects of AI tool should undergo a compatibility mode model which need to be designed in such a manner that goes compatible with legal regulations of the concerned country that can enhance the validity and authenticity of the data and information's.

**Hypothesis H1A:The Impact of Regulations on IT infrastructure and AI law through Ethical management**

From the figure 3.2C Where ethical management is the mediator based on regulations towards the AI IT law and infrastructure

From utilising the sobel test T value can be determined by  $T \text{ value of IT} = (T \text{ Value Of Rai} * T \text{ Value Of Em}) = 0,412 * 0.603 = 0.2483$ , which can be stated that T value is not falling near to specified value hence it is not significant. Hence regulations has no indirect effect of AI IT through EM.

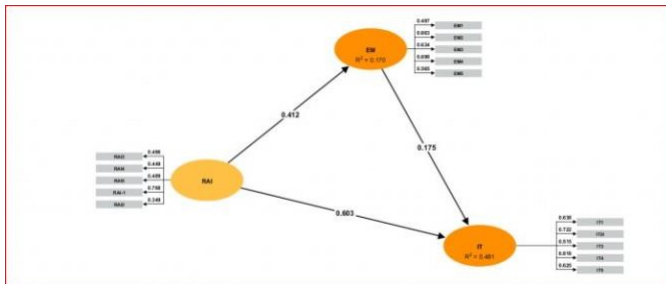

figure 3.1C: Impact of Regulations on IT infrastructure and AI law through Ethical management

### 3.2 hypothesis 2: Discussion:

The Variable ethical management has been determined with study of literature alongside a reason to depict the trust factor decrease in humans by utilising the AI tools in financial technology. The data has to be ethical but far more considering the past data the data seems to be of no control and no correlations with needed output a human expects, which can otherwise termed as an error in the formula of data mining in AI tech Some evidence that could relate with why ethical management system needs to be concentrated to enhance the efficiency of the utilising AI tools in the future or present era is

1. Uncertainties,
2. Technological constraints
3. Robust policy
4. Data protection
5. Transparency, accountability, and human involvement.
6. Harnessing ai,
7. Blockchain, ml,
8. Human ingenuity
9. Adoption of ai-driven security
10. Regular ethical hacking exercises
11. Ethical implications of ai in cybersecurity
12. Information systems security
13. Strong ethical standards and
14. Creative defence mechanisms

*Outcome*

The hypothesis generation

H2: To test the ETHICAL MANAGEMENT of AI influence the AI Legal infrastructure and innovation landscape.

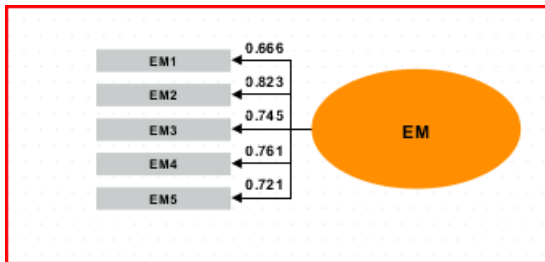

Figure 3.2A: Loading estimates for determinants of Ethical management

The figure 3.2 A shows the significant effect of the ethical management of AI influence the AI Legal infrastructure and innovation landscape with factors like eco friendly,time saving tool,AI tool standardization,block chain machine learning and performance indicator etc.

Hypothesis1(H2): the Ethical management of AI influence the AI Legal infrastructure and innovation landscape.

Research question: How significantly does the Ethical management of AI influence the AI Legal infrastructure and innovation landscape				
Hypothesis1(H2): the ethical management of AI influence the AI Legal infrastructure and innovation landscape				
No	Determination of hypothesis	Loading s	t-values t > 2.59	Inference on Loadings
		> 0.8 Strong 0.5 < L < 0.8 Moderat e	Strongly Significant	
H2a	AI tools are use friendly to perform financial operations	0.666	1.38	Moderate - significant t
H2b	AI tool save time while utilizing in the areas of fintech.	0.823	1.95	Strong- significant t

H2 C	AI tool speculate with ethical standardization and tranquility	0.745	1.64	Strong-significant
H2d	AI determine robust mechanisms to boost the AI error issues with blockchain machine learning	0.761	1.788	Strong-significant
H2e	Performance of AI fintech tool is very high	0.721	1.511	Strong significant

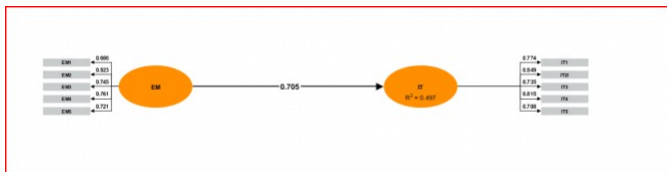

Figure 3.2C: Effect of Ethical management AI on IT Infrastructure and law

**H2-To test the effect of ethical management of AI (EM) on IT AI infrastructure innovation and Law(IT) in the international finance**

The relationship between the ethical management of AI over IT law and infrastructure plays a crucial role in terms of determining the relationship with T VALUES 0.705, WHERE the ethical management is influencing its impact over AIIT law and infrastructure.

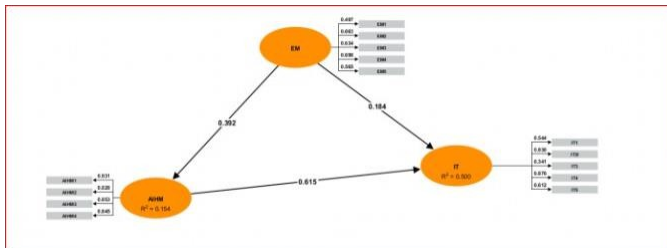

figure 3.2B: Impact of ethical management on IT infrastructure and AI law through Human brain and psychology

**Hypothesis H2A:The Impact of ethical management on IT infrastructure and AI law through AI human psychology.**

From the figure 3.2C Where human psychology AI is the mediator based on ethical

management towards the AI IT law and infrastructure

From utilising the sobel test T value can be determined by  $T \text{ value of } IT = (T \text{ Value Of } aihm * T \text{ Value Of } Em) = 0.392$

$*0.615 = 0.241$ , which can be stated that T value is falling near to specified value hence it is significant. Hence ethical management has indirect effect of AI IT through human psychology AI.

The concentration towards the Gen AI terminology in ethical management could enforce the stability in finance and financial management systems by providing a strong foundation to detach the burden of hacking, cyber threats, unethical standards determination of AI tools in fintech towards providing a AI ethical landscape in terms of improving the factor IT integrity where the data input and data output undergoes a rigorous testing of what if and if analysis which can help us to determine the standard error and negative outcomes before heading the tested data in information systems and congruence towards the solutions presented in terms of answer for questioning the credibility and authenticity of data and information's.

### *Preposition*

The key performance indicator that can evolve the basic ethical standards of utilising tools can be obtained with proportionate outcome with perspective of providing the logic output to humans by rectifying the system error and should enhance the sense of acceptance in with ethical concerns can either way create a clarity in determining the advanced and appropriate decision by adopting ways like decision tree, clustering and machine learning tools in data and information asymmetry which can predict the future outcome by Amending the ethical rules and regulations of AI in terms of considering the societal political, technological legal and economic aspects of the country, which may enhance the durability of utilising the AI tools.

### *3.3 Hypothesis 3: Discussion*

The determination of systematic risk of the AI tools do play a crucial role in demanding the Outcome to be led free of risk based on the data structure and data architecture, which further need data science and analysis which can be done by adopting a data mining steps to deliberate the risk causing factors in AI technologies. Some of the risk the AI has faced while in the past includes the factors like

1. Professional codes
2. Standards of business behaviour
3. Consult practitioners
4. Risk Management
5. Cybersecurity risks
6. Risk analysis.
7. Fraud and labour employment
8. Fear
9. Human emotional failure
10. Tool failure
11. Cost and finance crisis
12. Wrong adoption of ai tool
13. Human rror

14. Cost
15. Man
16. Machine
17. Cultural variances

*Outcome*

<p><b>Research question:</b> How significantly does the Systematic risk management of AI influence the AI Legal infrastructure and innovation landscape</p> <p>Hypothesis1(H3): the systematic risk management of AI influence the AI Legal infrastructure and innovation landscape</p>				
No	Determination of hypothesis	Loadings > 0.8 Strong 0.5 < L < 0.8 Moderate	t-values t > 2.59 Strongly Significant	Inference on Loadings
H3a	the human emotional dilemma can be determined by utilizing AI tools	0.747	1.46	Strong-significant
H3b	Adoption of right AI technology can ensure right output to ensure effective decision making	0.747	1.47	Strong-significant
H3C	cyber law and regulations minimize the cyber threats in businesses	0.720	1.400	Strong-significant
H3d	The architecture of AI tools can be effectively managed by cost management risk measures	0.855	2.037	Strong-significant

**The hypothesis generation**

**H3:To test the Systematic risk of AI influence the AI Legal infrastructure and innovation landscape.**

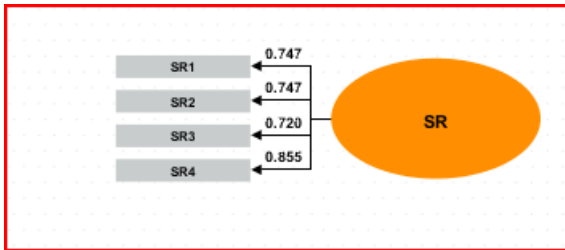

Figure 3.3A: Loading estimates for determinants of systematic risk

The figure 3.3 A shows the significant effect of the systematic risk management of AI influence the AI Legal infrastructure and innovation landscape with factors like human emotions, management risk cyber threats of AI tool,Ai adaptation tools etc.

**Hypothesis1(H3): the systematic risk of AI influence the AI Legal infrastructure and innovation landscape.**

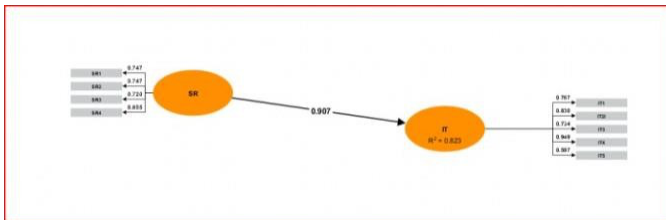

Figure 3.3C: Effect of systematic risk AI on IT Infrastructure and law

The relationship between the systematic risk management of AI over IT law and infrastructure plays a crucial role in terms of determining the relationship with T VALUES 907, WHERE the systematic risk management is influencing its impact over AIIT law and infrastructure.

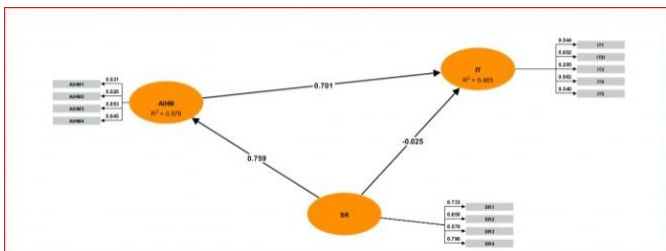

figure 3.3B: Impact of Systematic risk on IT infrastructure and AI law through human psychology

**Hypothesis H3A:The Impact of systematic risk management on IT infrastructure and AI law through AI human psychology.**

From the figure 3.3B Where human psychology AI is the mediator based on systematic risk management towards the AI IT law and infrastructure

From utilising the sobel test T value can be determined by T value of  $IT=(T \text{ Value Of } aihm * T \text{ Value Of } sr)=0.701$

$*0.759=0.5321$ , which can be stated that T value is falling near to specified value hence it is significant. Hence systematic risk management has indirect effect of AI IT through human psychology AI.

Addressing the risk factors such as human errors, financial and technological constraints, the tools installation difficulties, the scalability of project, system failures, the human emotional factors like fear, trust lack, the coding error, wrong automotive data generation, the fraudulent risk it can and should be minimized by adopting the risk analysis matrix that can depict the future adverse outcome of these specified errors, hence to transform the ai tools to be efficient and useful in productivity and efficiency of the desired tool, the output to overcome the negative aspects of risk and details we can be Ready to face the adverse effects of outcome to handle the situations in a more structured manner and less loss in terms of money, man machine and infrastructure . Hence analyzing and predicting the systematic risk are just going to provide us the prediction towards how the risk need to be handled and managed to face the adverse side of utilising AI tools in a wrong way.

#### *Preposition*

The general outcome that need to be addressed by minimizing the risk are prolonged usage of error less coding and programming, human error reduction and cost savings which can efficient the usage of AI tools , the men machine money are basic three factors that are always related to specified risk factors detailed above where the capacity to adhere the negative adverse failure actions caused by utilising the ai tools can be predicted and managed henceforth the need for model and conceptual framework to undergo any adverse situations caused due to these errors need to be addressed by providing the management of risk in AI tool framework that can interchange the negative affects to positive outcomes, which can be beneficial to humans and society. Error identification methods need to be implemented in order to enhance the credibility of the AI tools and technology where the failure can be predicted before and reduce the cost used in risk and failure of products.

### **3.4 Hypothesis 4: Discussion**

The artificial intelligence are the replica of human brains, the neural network has the capacity to function in such a manner that the human mind does the actions and decisions with logic and practicability, hence with comparing the AI the aspect of duplicating human mind do have some drawbacks, some of them were the

1. Continuous improvement mindsets
2. Transparency, accountability, and human involvement
3. Human ingenuity
4. Trust
5. Fostering a culture of cybersecurity
6. Collaboration among stakeholders
7. Robust AI to avoid any adverse outcomes related to economic, ethical and social issues policymakers and enhance the stability of the financial system
8. Lack of skilled employees
9. Compatibility issues with legacy systems,
10. Cybersecurity and criminal law
11. Technological development and legal rationality
12. Architecture of “digital laws
13. Enactment of specific regulations for Generative AI.

#### *Outcome*

**The hypothesis generation**

**H4: To test the Human psychology of AI influence the AI Legal infrastructure and innovation landscape.**

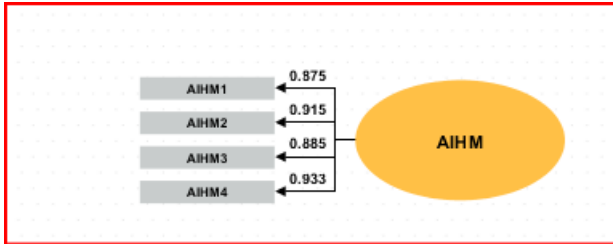

Figure 3.4A: Loading estimates for determinants of Human psychology

The figure 3.4 A shows the significant effect of the human psychology management of AI influence the AI Legal infrastructure and innovation landscape with factors like digital AI fintech law, cyber law, emotions, legal rationality, cyber security, AI laws, cyber threats of AI tool,s etc.

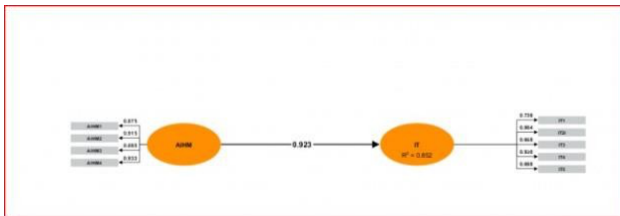

Figure 3.4B: Effect of human psychology AI on IT Infrastructure and law

Research question: How significantly does the AI Human psychology and brain influence the AI Legal infrastructure and innovation landscape Hypothesis1(H4): the AI human psychology and brain influence the AI Legal infrastructure and innovation landscape				
No	Determination of hypothesis	Loadings > 0.8 Strong 0.5 < L < 0.8 Moderate	t-values t > 2.59 Strongly Significant	Inference on Loadings
H4a	Digital AI fintech law need to be enhanced with the solicitation towards psychological emotional constraints of human brain and logic	0.933	2.79	Strong-significant

H4b	AI driven behavioral environment leads the technological advancement and legal rationality	0,915	3.5	Strong-significant
H4C	strengthening AI Laws and cybersecurity leads to effectiveness of Fintech	0.885	3.20	Strong-highly significant
H4d	strengthening generative AI regulations leads the organization culture	0.993	4.49	Strong-highly significant

The relationship between the human sychology of AI over IT law and infrastructure plays a crucial role in terms of determining the relationship with T VALUES 923, WHERE the systematic risk management is influencing its impact over AIIT law and infrastructure.

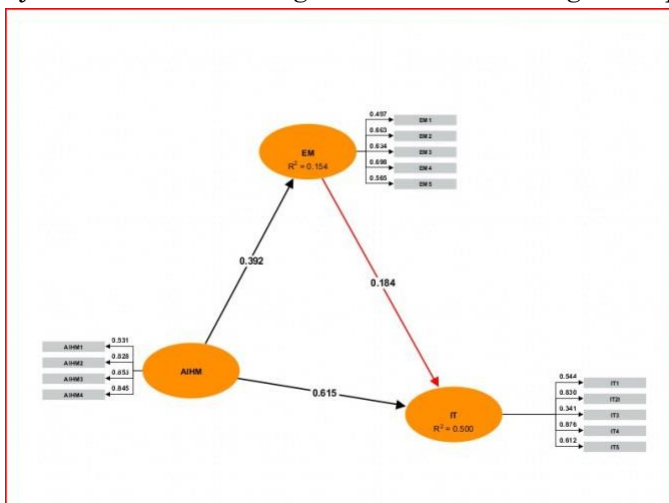

figure 3.4C: Impact of Human psychology on IT infrastructure and AI law through Ethical management

**Hypothesis H4A: The Impact of human psychology on IT infrastructure and AI law through AI human psychology.** From the figure 3.2C Where human psychology AI is the mediator based on ethical management towards the AI IT law and infrastructure From utilising the sobel test T value can be determined by T value of  $IT = (T \text{ Value Of } ai hm * T \text{ Value Of } Em) = 0.392$

$*0.61 = 0.241$ , which can be stated that T value is falling near to specified value hence it is significant. Hence ethical management has indirect effect of AI IT through human psychology AI.

**Hypothesis1(H4): the human psychology of AI influence the AI Legal infrastructure and innovation landscape**

Psychology is the term used to define the way the human mind reacts to the environment under various circumstances and situations. The positive way of facing a situation of conflict by an individual considering the overall profit of the customs clearance of goods and procedures is defined as psychological capital. Understanding human nature is psychology, it is the process of explaining the nature of the human considering the nature of the behaviour of human-based in the environment he has been handling. Psychology basically concentrates on complexity, integrity, and sociality. Emotional psychology the concept of triggering one’s emotion to reach and attain a goal is termed emotional psychology. Emotion psychology can be classified into two forms Reappraisal and suppression. Reappraisal of emotions: a re-evaluation of emotion acting stimuli to change its acting or behaviour based on their thoughts. More sharing of emotions and interpersonal effects on emotional behaviour and evaluation of emotions. Reappraisal of one’s emotions can eventually increase the quality of work and can improve self-satisfaction towards his career in other terms job satisfaction. In other terms, suppression are the control of emotions or neutralizing emotional behaviour in other terms less sharing of emotions. Regulations of expressive behaviour and interpersonal relationship, motivations of behaviour to express one state of intentions and providing incentives of others behaviour.

*Preposition*

Research question: How significantly does the AI Human psychology and brain influence the AI Legal infrastructure and innovation landscape Hypothesis1(H5): the AI human psychology and brain influence the AI Legal infrastructure and innovation landscape				
No	Determination of hypothesis	Loadings > 0.8 Strong 0.5 < L < 0.8 Moderate	t-values t > 2.59 Strongly Significant	Inference on Loadings
H5a	IT law technology and infrastructure the invention and innovation is mandatory for effective deployment of AI	0.793	2.48	Strong-significant

H5b	Good AI operational manual ensure effective utilization of AI	0.845	4.10	Strong-highly significant
H5C	training from experts is mandatory for effective deployment	0.805	2.66	Strong-

*The relationship between cultural value and emotional regulation.*

Social complexity, while considering the organization there exists always the social complexity in the organization. The people involved in a project require social interactions In order to pursue their work. Need for social order Culture as meaning and information systems Value related to emotions Value related to interpersonal relationship Norms regarding emotional regulation. Emotion regulation contributes to inter-structural adjustment Reappraisal mainly requires group work organization, management, and social group work, relating to the people working in the industry. Suppression relates to power distance, long-term orientation, conflicts and uncertainty. Cultural values are nothing but the combination of reappraisal and suppression and the relationship between them.

*3.5 Hypothesis 5 Discussion*

The IT infrastructure plays a critical role in analysing AI in fin tech and the aspect of adopting a new technology in to the present method of traditional approach to financial domain still needs technological advancement to adhere the system compatibility and scalability to adopt those technological advancements, hence AI are huge and need more investment there need a special considerations to adopt those technology where humans need to get to understand those software’s easily which can be only done by improving the IT infrastructure.

Some of the variables that directly or indirectly influence the IT infrastructure are

- 1) innovate and Adapt
  - 2) scalable AI solutions
  - 3) resource allocation
  - 4) AI-enabled infrastructure
  - 5) Scalable AI solutions
  - 6) Reliance on technology expands
  - 7) training and maintenance of systems
  - 8)integrated infrastructure
  - 9)'AI-powered systems robust and flexible
  - 10)feasibility of in-house development of AI systems,
  - 11)protecting digital infrastructures and systems
- Outcome:*

**The hypothesis generation**

**H4A: To test the dependency of AI influence the AI Legal infrastructure and innovation landscape.**

	and utilization of the AI fintech			
H5d	The three aspects of legal, psychology and innovation are mandatory for effective results of generative AI in fintech.	0.840	4.113	Strong-highly significant
H5e	Future Human robots and Human cognitive brains are effectively used for breakthrough outcomes in business with fintech	0.606	1.3776	Strong-significant

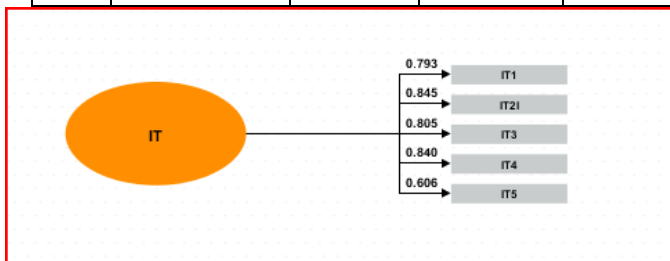

Figure 3.5aA Loading estimates for determinants of IT

The figure 3.5 A shows the significant effect of AI Legal infrastructure and innovation landscape with factors like digital AI fintech law, ai law, innovation, legal rationality, AI tool skills, training AI cost cyber security, AI laws, cyber threats of AI tools etc.

The need to improve the technological compatibility will be fulfilled only by adopting the technological infrastructure by imposing a budget friendly introduction to software

technology compliance that could enhance the user friendly nature to humans who have get adapted to AI technology in to their day today life The need to invest in those AI technology needs proper project management techniques which can help in creating a way to make the IT infrastructure to be more sustainable related with finance and fintech

### *Preposition*

The need for It infrastructure investment to adopt AI technology is need to designed and have to make sure that each human are able to understand it easily and we should reduce the complexity of usage of AI technology and testing. Hence while mitigating the difficulty in implementing the infrastructure to adapt AI we should make sure that it is human friendly and of out of error with 0%.Design/ methodology /approach The contribution towards achieving the sustainable ai in finance needs a regulated framework that concepts the ratio imbalance between ai mechanisms with machine intelligence in compliance with the regulatory and legal aspects in the economy encompassing of human values, the variable that directly or indirectly influence the legal repository attributes of ai tools in finance domain are cyber attacks in fintech; that disrupts the privacy & security of technological data; by creating the cyber threats and systematic risks, where the current criminal legal technology compliance in ai aspects are not advanced to determine the fraud detection and fails to engraved the human trust and security factor of emotions. The methodology to determine the role of drawback of ai technology of fintech in legal compliance can be exceptionally witnessed by adopting the qualitative method of data analysis through indulging the case study review findings by skimming

40 case studies and adopting quantitative research with collection of data from stake holders like AI data science managers, CEO, and AI researchers and IT companies employee who work with AI concepts.. After analyzing the case studies the high priority independent indicators that need to be addressed in the context of ai in fintech is legal regulatory and policy framework of ai that has the dependent variables such as safety ,user privacy factor, ethical factor of systematic risks, the role of authoritative regulatory body of ai human psychology ai policy ,ai laws ,& ai infrastructure, innovation research.

### *Discussion*

This research has been explained based on case study analysis with consent reviewing and skimming of 40 journals that has clearly stated the advancement of AI tools in fintech, we could rationalize the data obtained in mere information basis and with the relevant collection of data mining through the case studies it has been theoretically significant that there is a need for legal regulatory, ethical and secure framework for AI in finance and other do mains, the cyber-attacks and data leakage to create a greater impact of danger to business in state or regional or national or international level of economy where at the end its human value and beliefs is what going to suffer in adverse output with utilising the AI, hence the three dimensions which need at most detailing for proper utilization of AI too, are, legal and regulatory aspects, human psychology and innovation aspects and finally cyber security and TECHNOLOGY MANAGEMENT aspects.

The quantitative analysis methods have also been carried out by conducting a pilot study based on with derivative of those dependent variable that influences the efficiency of AI(EAI) fintech tools are ,**RAI**: Regulations in Usage of AI tool, **EM**: Ethical management in Usage of AI tool, **SR**: Systematic Risk analysis of AI tools, **AIHM**: Artificial intelligence

and human Psychology, IT:IT infrastructure and AI .obtained the respondents from 50 people which made the real impact of the raw data being valid

From the descriptive statistical analysis has been conducted to determine the relations, regression\, variance between the variables and their influence on AI infrastructure and law in the aspect of how the legal arena can be modified in order to strengthen the cyber law and regulations. from the aspect of using the software tools like ADANCO a advanced tools that could determine the correlations between the variables.

## 5. LIMITATIONS AND FUTURE SCOPE OF RESEARCH

The results has its implications for implementing the legal framework to each and every country to imply the AI tool in all domain has the practical complexity because the world is so diverse and in macroeconomic aspect the human values has the utmost priority which has its inbuilt religious, cultural beliefs and sentiments, scaling up legal framework to compile with world legal system needs a proper diverse common digital legal AI platform that collaborates with basic concept of humanity and people beliefs of human values that need to implemented in terms of law or legal ai , but that need more vigorous support of data mining and human acceptance that should proportionately expand human mindset to growth mindset, the broader perspective of accepting things which takes time, the aspect of being AI tool to be designed to overcome cyber- attacks need a implementation of data security for various aspects and services classifications which can be determined by classifying the humans with age, race , ethnicity, color, and cultural beliefs where the data authentication can be filtered with legal and regulations followed in their own respective country and economy, that need support from government that is more complex job specially in developing countries like India. Human mind plays a complex role in understanding and conceptualize AI tool, hence its not easy for humans to use the tool once it comes to market, we can never predict how the tool will enhance the efficiency of the business and economy because the entire world need more productivity, efficiency and less labor etc. Human emotions can either make a positive use or can face a regressive effect of using AI tool in wrong manner her proper guidance is required THIS research has predominantly concentrated on legal, ethical security, psychological aspects of ai tools that can very well compile with the current advancement era in AI technology with preventing it from cyber-attacks and threats etc. The revised seteh framework abides the three factors that can improve the user-friendly platform of AI tool usage by humans.

## 6. CONTRIBUTION TO RESEARCH

The application towards revolutionizing the impact of AI in the arena of global Financial technology applications needs a support and solutions towards detailing to concerns faced with cyber-attacks and fraud detections where the policies related to AI Information technology needs vibrant AI legal applications towards security and authenticity in money transferring and to validate the true data with the useful applications of AI in fintech like determining the intellectual predictions towards investing in stocks , having a genre of E portfolio of family savings and wellbeing that could impact on developing the strategy for how AI could entropy the financial services landscape in concentration towards determining the amendment of AI legal and policies towards the sustainable and risk free utilization of AI in financial services. In recent years we could see that the major drawbacks faced by utilising the AI tools are cybercrime, sabotage, hacktivism, and

information warfare and the attacking techniques used are 0-day, Account cracking, DDoS, malware, Multiple threats, Phishing, phone hacking, social engineering, SQLi, vulnerabilities etc. which creates a panic and trust issues with humans utilising AI in global finance, some of the major services that are directly or indirectly being played a victim includes services like Finance, Automative, critical infrastructure, consulting, health, online services cloud, Government contractors and services, Entertainment and news, retail, trade, customs , export and import industry etc. Ai being a advanced tool which has the capacity to develop the technology in economy towards how the AI legal, psychology and AI human resource management policies could directly or indirectly determine the solutions there are still seem to have a need of new legal and policy amendments towards AI tools to utilise it in greater efficiency in application to business administration services. The applications of legal landscape infrastructure can entertain a significant positive correlation in humans ease in utilising day to day activities through AI platform, thus could impact the economic development in terms of GDP and standard of living of people.

The application of AI in risk needs a broader engagement in determining the way in and out of how to conceptualize the detailed impact of aversion in financial and other services landscape. In most industries AI is determined to create risk and technical complexity to adapt to the technical environment due to the cause of information asymmetry. The model that can enhance the risk aversion of utilising AI tools in fintech and other services can be addressed by adopting a risk AI model that has the direct and indirect factors related to distinct ideology of how risk management model tools have the wider significance towards mitigating risk in AI finance technology and services.

Some of the advantages in implementation of the SETEH framework can gain its supportive hypothesis of implementation that are due to the sequential modelling analysis done with aspect of how regulations, systematic risk, ethical management and finally Human psychology could influence the congruence of the need to reform the cyber law and information technology law acts to ensure a human privilege to stay in peace and emotionally strong to determine the positive aspect of AI tools to enhance his or her day today technological financial and other digital activities in a very

- Efficient manner
- Being in ease to use
- Trust the AI guidance
- Information Genuity
- Being humanity based
- Cost and time efficient

The congruence between AI regularities with respect to sustainability in finance need a gesture of correlation with the factors involving like legal compliance, IT infrastructure, ethical and psychological compliance which can be attained through mediator factors like Law for security, tranquility frame work design that may or may not be directly related to efficiency in laying cybersecurity framework model The conceptual framework has been designed in order to determine a variant result and solutions to the risk and unethical actions that are occurring due to utilization of AI and hence the role of Law, regulations and technical utilization in ways with addressing AI tool error with proper practice of adapting HR policies and ethical considerations that can enhance the efficiency of utilising

AI tool with implementation of Cyber security frameworks.

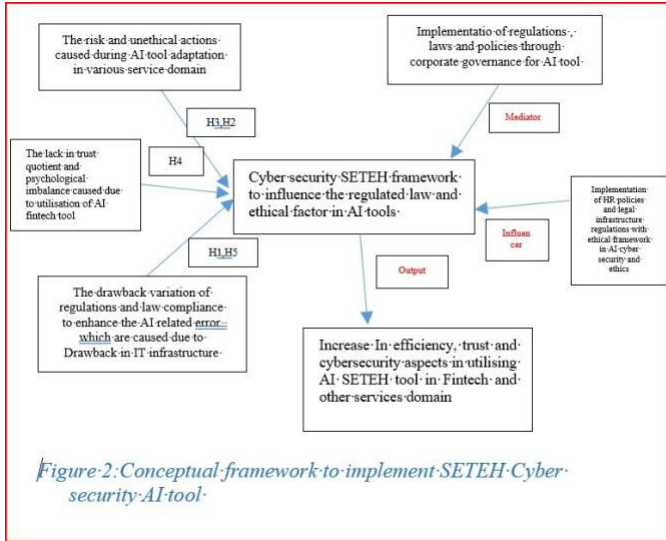

Figure 2: Conceptual framework to implement SETEH-Cyber security AI tool

7. CONCLUSION

With the conduct of AI tool legal framework seteh , the broader expectation to address the need for privacy and security towards data leaks and cyber hacks, the human values, laws, policy and innovation Of utilising the advancement tools of AI can stabilize the economy in aspects like wealth, finance, GDP, poverty, technology that can directly or indirectly influence the standard of living of people in the society, if with the condition that they utilise with authenticity, law abiding, and ethical in actions . Hence in short, we could state the future world is technological advancement and stability towards finance has the key major role in growth of economy in innovation and research, and technology advancement at global scale.

From the basic aspect of determining the role of IT innovation infrastructure legal landscape as the enhancement criteria, we could determine that there is a need to evaluate the legal area such as cyber laws, security , information authentication along with human emotional stability considerations in utilising AI tools in fintech still needs a further rule enactment and technology law refinement to ensure that the data or information provided to public needs a seteh frame work where the safety, authenticity, ethics, humanity and tranquility aspects of data of individuals has been protected and safeguarded by the cyber law and information and technology act ith intact modulation of people well being and safeguard them from loss in money, peace and ensure the future AI area a place to deploy trust, humanity and peace within nations and country. Jai Hind

REFERENCES

[1] 'Ajay K. Agrawal, Joshua S. Gans, and Avi Goldfarb, Economic Policy for Artificial Intelligence, June 2018, NBER Working Paper No. 24690 NBER Working Paper No. 24690

[2] 'Avi Goldfarb and Daniel Trefler (2019) , "Artificial Intelligence and International Trade" University of Chicago Press , 463 – 492, L: <http://www.nber.org/books/agra-1>

[3] Al-Baity HH. The Artificial Intelligence Revolution in Digital Finance in Saudi Arabia: A Comprehensive Review and Proposed Framework. Sustainability. 2023; 15(18):13725. <https://doi.org/10.3390/su151813725>

- [4] 'Alnaser, F. M., Rahi, S., Alghizzawi, M., & Ngah, A. H. (2023). Does artificial intelligence (AI) boost digital banking user satisfaction? Integration of expectation confirmation model and antecedents of artificial intelligence enabled digital banking. *Heliyon*, 9(8).
- [5] AL-Dosari, K., Fetais, N., & Kucukvar, M. (2024). Artificial intelligence and cyber defense system for banking industry: A qualitative study of AI applications and challenges. *Cybernetics and systems*, 55(2), 302-330.
- [6] 'amos, S., Ellul, J. Blockchain for Artificial Intelligence (AI): enhancing compliance with the EU AI Act through distributed ledger technology. A cybersecurity perspective. *Int. Cybersecur. Law Rev.* 5, 1–20 (2024). <https://doi.org/10.1365/s43439-023-00107-9>
- [7] 'AlAmayreh, E., Almajali, D., AlSmadi, L., Masadeh, R. E., Al-Sherideh, A., & Majali, S. (2023). Antecedents of understanding the investors' acceptance of artificial intelligence: Perceptions from Jordanian context. *International Journal of Data and Network Science*, 7(4), 1861-1874.
- [8] Biasin, E., & Kamenjašević, E. (2024). Regulatory Approaches Towards AI-Based Medical Device Cybersecurity: A Transatlantic Perspective. *European Journal of Risk Regulation*, 1-11.
- [9] 'Biswas, S., Bhattacharya, M., & Kumar, D. (2024). Antecedents and Consequences of Earnings Management: A Systematic Review of the Banking Sector in Developed and Developing Countries. *Australasian Accounting, Business and Finance Journal*, 18(2), 196-236.
- [10] Dopamu, O., Adesiyani, J., & Oke, F. (2024). Artificial intelligence and US financial institutions: Review of AI- assisted regulatory compliance for cybersecurity.
- [11] 'Eren, B.A. Antecedents of robo-advisor use intention in private pension investments: an emerging market country example. *J Financ Serv Mark* (2023). <https://doi.org/10.1057/s41264-023-00229-5>
- [12] George, A. S. (2023). Securing the future of finance: how AI, Blockchain, and machine learning safeguard emerging Neobank technology against evolving cyber threats. *Partners Universal Innovative Research Publication*, 1(1), 54-66.
- [13] 'Goswami, M., Jain, S., Alam, T., Deifalla, A. F., Ragab, A. E., & Khargotra, R. (2023). Exploring the antecedents of AI adoption for effective HRM practices in the Indian pharmaceutical sector. *Frontiers in Pharmacology*, 14, 1215706.
- [14] 'Giudici, P., & Raffinetti, E. (2022). Explainable AI methods in cyber risk management. *Quality and reliability engineering international*, 38(3), 1318-1326.
- [15] 'Jason Furman and Robert Seamans, AI and the Economy, June 2018, NBER Working Paper No. 24689
- [16] 'Joushua S., Grans and AV Goldfrab, The interaction between psychology and AI considering the aspects of Epistemological and empiricism ,2022, NBER WORKING PAPER SERIES.
- [17] Jiang, C., & Broby, D. (2021). Mitigating cybersecurity challenges in the financial sector with artificial intelligence.
- [18] 'Judijanto, L., Tubagus, M., Hasibuan, R., Mustajab, D., & Rosid, A. (2024). Integration Of Blockchain Technology in The Financial System: Assessing Its Impact on Efficiency, Security, And Stability of Financial Markets. *International Journal of Economic Literature*, 2(1), 41-53.
- [19] 'Kaya, F., Aydin, F., Schepman, A., Rodway, P., Yetişensoy, O., & Demir Kaya, M. (2024). The roles of personality traits, AI anxiety, and demographic factors in attitudes toward

- artificial intelligence. *International Journal of Human–Computer Interaction*, 40(2), 497-514.
- [20] 'Kay, A., Hutcherson, C., Keene, C., Zhang, X., & Terwilliger, M. G. (2021). How financial Institutions address cybersecurity threats: A critical analysis. *Issues in Information Systems*, 22(1), 63-74.
- [21] Kazachenok, O. P., Stankevich, G. V., Chubaeva, N. N., & Tyurina, Y. G. (2023/12//). Economic and legal approaches to the humanization of FinTech in the economy of artificial intelligence through the integration of blockchain into ESG finance. *Humanities & Social Sciences Communications*, 10(1), 167.doi:<https://doi.org/10.1057/s41599-023-01652-8>
- [22] 'Koulu, R., Sankari, S., Hirvonen, H., & Heikkinen, T. (2023). Artificial intelligence and the law: can we and should we regulate AI systems?. In *Research Handbook on Law and Technology* (pp. 427-449). Edward Elgar Publishing.
- [23] 'Li, Z. (2023). The dark side of ChatGPT: legal and ethical challenges from stochastic parrots and hallucination. *arXiv preprint arXiv:2304.14347*.
- [24] 'Masadeh, R. E., Almajali, D., Al-Okaily, M., AL-Sous, N., & Al-Mousa, M. (2024). Antecedents of cloud-based financial information systems usage: An integrated model. *International Journal of Data and Network Science*, 8(1), 125-138.
- [25] 'Marda V. 2023 Artificial intelligence policy in India: a framework for engaging the limits of data-driven decision- making. *Phil. Trans. R. Soc. A* 376: 20180087
- [26] 'Martin Beraja, Andrew Kao, David Y. Yang, and Noam Yuchtman, Exporting the Surveillance State via Trade in AI, September 2023, NBER Working Paper No. 31676, JEL No. E0,L5,L81,O30,P0
- [27] 'Manser Payne, E. H., Peltier, J., & Barger, V. A. (2021). Enhancing the value co-creation process: artificial intelligence and mobile banking service platforms. *Journal of Research in Interactive Marketing*, 15(1), 68-85.
- [28] Milana, Carlo; Ashta, Arvind. *Strategic Change*. May 2021, Vol. 30 Issue 3, p189-209. 21p. 5 Diagrams, 3 Charts, 1 Graph. DOI: 10.1002/jsc.2403. , Database: Business Source Complete
- [29] 'Mefoute Badiang, A., & Nkwei, E. S. (2024). Mobile banking adoption its antecedents and post-adoption effects: the role of consumers status orientation in an African context. *Cogent Business & Management*, 11(1), 2321787.
- [30] 'Müller, L. S., Nohe, C., Reiners, S., Becker, J., & Hertel, G. (2024). Adopting information systems at work: a longitudinal examination of trust dynamics, antecedents, and outcomes. *Behaviour & Information Technology*, 43(6), 1096-1128.
- [31] Novelli, C., Casolari, F., Hacker, P., Spedicato, G., & Floridi, L. (2024). Generative AI in EU Law: Liability, Privacy, Intellectual Property, and Cybersecurity. *arXiv preprint arXiv:2401.07348*.
- [32] Olweny, F. (2024). Navigating the nexus of security and privacy in modern financial technologies. *GSC Advanced Research and Reviews*, 18(2), 167-197.
- [33] Oyewole, A. T., Adeoye, O. B., Addy, W. A., Okoye, C. C., Ofofode, O. C., & Ugochukwu, C. E. (2024). Promoting sustainability in finance with AI: A review of current practices and future potential. *World Journal of Advanced Research and Reviews*, 21(3), 590-607.
- [34] 'Pattnaik, D., Ray, S., & Raman, R. (2024). Applications of artificial intelligence and machine learning in the financial services industry: A bibliometric review. *Heliyon*.
- [35] 'Prikshat, V., Malik, A., & Budhwar, P. (2023). AI- augmented HRM: Antecedents

- assimilation and multilevel consequences. *Human Resource Management Review*, 33(1), 100860.
- [36] 'Rissland, E. L., Ashley, K. D., & Loui, R. P. (2003). AI and Law: A fruitful synergy. *Artificial Intelligence*, 150(1- 2), 1-15.
- [37] 'Stephen B Goldberg, F. E. (2020). *Dispute Resolution: Negotiation, Mediation, Arbitration and other process*. Frederick: Aspen. Retrieved from [https://books.google.co.in/books?id=tAGBEAAAQBAJ&newbks=0&printsec=frontcover&pg=PR21&dq=arbitration+and+conflict+resolution&hl=en&source=newbks\\_fb&redir\\_esc=y#v=onepage&q=arbitration%20and%20conflict%20resolution&f=false](https://books.google.co.in/books?id=tAGBEAAAQBAJ&newbks=0&printsec=frontcover&pg=PR21&dq=arbitration+and+conflict+resolution&hl=en&source=newbks_fb&redir_esc=y#v=onepage&q=arbitration%20and%20conflict%20resolution&f=false)
- [38] 'Senathirajah, A. R. B. S., bin S Senathirajah, A. R., Alainati, S., Haque, R., Ahmed, S., Khalil, M. I., & Chowdhury, B. (2024). Antecedents and Consequence of Trust-Commitment Towards Artificial Based Customer Experience. *UCJC Business and Society Review (formerly known as Universia Business Review)*, 21(80).
- [39] 'Saßmannshausen, T., Burggräf, P., Wagner, J., Hassenzahl, M., Heupel, T., & Steinberg, F. (2021). Trust in artificial intelligence within production management—an exploration of antecedents. *Ergonomics*, 64(10), 1333-1350.
- [40] 'Thammareddi, L., Agarwal, S., Bhanushali, A., Patel, K., & Venkata, S. (2023). Analysis On cybersecurity threats in modern banking and machine learning techniques for fraud detection.
- [41] 'Udeh, E. O., Amajuoyi, P., Adeusi, K. B., & Scott, A. O. (2024). The integration of artificial intelligence in cybersecurity measures for sustainable finance platforms: An analysis. *Computer Science & IT Research Journal*, 5(6), 1221-1246.
- [42] 'Umoga, U. J., Sodiya, E. O., Amoo, O. O., & Atadoga, A. (2024). A critical review of emerging cybersecurity threats in financial technologies. *International Journal of Science and Research Archive*, 11(1), 1810-1817.
- [43] 'vetlova, E. AI ethics and systemic risks in finance. *AI Ethics* 2, 713–725 (2022). <https://doi.org/10.1007/s43681-021-00129-1>
- [44] Wang, X. (2020, April). Criminal law protection of cybersecurity considering AI-based cybercrime. In *Journal of Physics: Conference Series* (Vol. 1533, No. 3, p. 032014). IOP Publishing.
- [45] 'Wong, L. W., Tan, G. W. H., Ooi, K. B., & Dwivedi, Y. (2024). The role of institutional and self in the formation of trust in artificial intelligence technologies. *Internet Research*, 34(2), 343-370.
- [46] Weber, P., Carl, K. V., & Hinz, O. (2023). Applications of explainable artificial intelligence in finance—a systematic review of finance, information systems, and computer science literature. *Management Review Quarterly*, 1-41.
- [47] Yigit, Y., Buchanan, W. J., Tehrani, M. G., & Maglaras, L. (2024). Review of Generative AI Methods in Cybersecurity. arXiv preprint arXiv:2403.08701.v
- [48] Zhang, D., Petrova, A., Trautmann, D., & Schilder, F. (2023, October). Unleashing the power of large language models for legal applications. In *Proceedings of the 32nd ACM International Conference on Information and Knowledge Management* (pp. 5257-5258).
- [49] 'Zapadka, P., Hanelt, A., Firk, S., & Oehmichen, J. (2020). Leveraging “AI-as-a-Service”—antecedents and consequences of using artificial intelligence boundary resources.